

ESC Code: 600419 (Black)

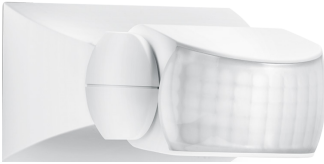

ESC Code: 600310 (White)

High-tech. Low Energy

Are you looking for best value sensor on the market? The IS 1 infrared motion detector comes with perfected technology, reliability and attractive design. The IS 1 can be mounted on the wall or ceiling and is the perfect solution for monitoring areas with precision targeting in front of buildings and on driveways. It also provides excellent quality of detection and can be tailored to the specific conditions on site.

Scan Here



Ideal Application:

- Entrance Areas
- Driveways
- Garage Entrances
- Outdoors
- Balcony

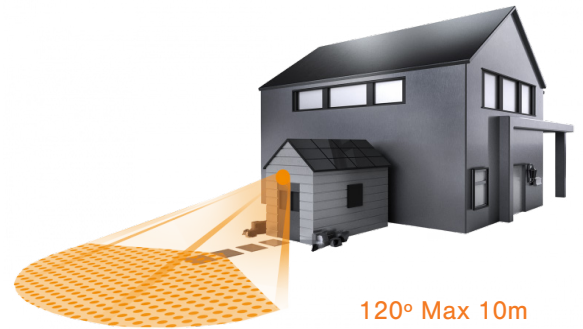

120° Max 10m

Dimensions (mm)	80 x 50 x 120
Detection Area	120°
IP Rating	IP54
Max. Reach	10m
Adjustment	60° / 180°
Stay on Time	8 Sec - 35 Min
Mounting Height	1.8 - 3.0m
Light Level Settings	2 - 2000 lx
Mounting	Surface Mount
Warranty	3 Years
Settings	Integrated Turn Wheels

Max.Load on Switched Relay Output (L')	
GLS	500W
LED	64W

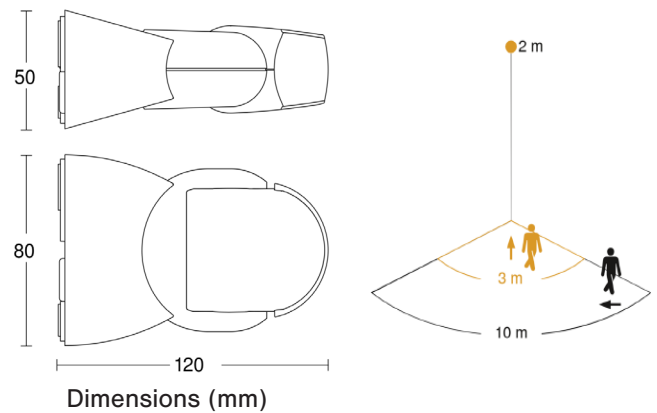

- Infrared Sensor
180°
- Max.10m
- 500W Max
- IP54
- 60° Horizontal
180° Vertical
- 2 - 2000 lux
- 8 Sec - 35 Min
- Ideal 2m
- Energy Saving